

MICRO-MAX

Back to Basics!

The X-Ray Film Processor for the new millennium...



Table Top X-Ray Film Processor

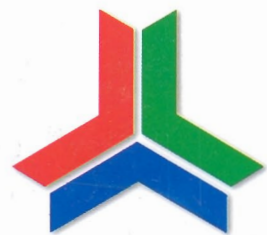

HOPE

MicroMAX SPECIFICATIONS

The Back to Basics features of the MicroMax are designed to deliver high-output for its compact size.

The MicroMax is value priced to ideally serve the moderate film developing needs of the private practice market, including medical and veterinary clinics, diagnostic and chiropractic care centers as well as mobile diagnostic applications.

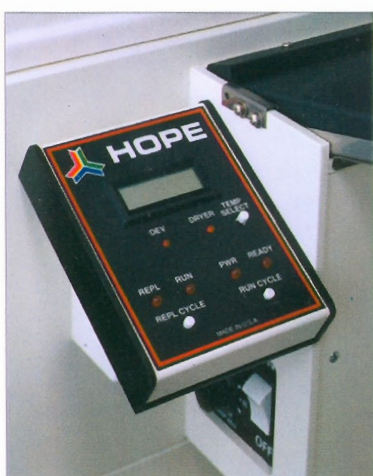

MicroMAX versatile features:

Compare for yourself...then come to HOPE

- MicroMAX utilizes Hope's unique low torque, no crossover hard roller transport system
- MicroMAX's quiet, powerful, low energy dryer easily dries film under any condition
- MicroMAX's "dual" automatic replenishment system may replenish either by measuring film area or by flooded replenishment with manual operation back-up!
- Automatic energy and water saving standby system with built-in jog feature. Manual operation back-up!
- Film may be delivered either on top or rear exit
- MicroMAX may be installed thru-the-wall at either feed or dryer end
- MicroMAX may be set up at different speeds from 90 to 135 seconds
- Plugs into any standard wall outlet
- Cold water operation - no hot water required!
- Separate drains provide for quick draining of solutions, closed loop operation and easy use of silver recovery systems
- Light tight feed tray reduces darkroom time and eliminates costly darkroom passage systems
- Digital display of developer and dryer temperatures
- Sales and service supported by factory trained worldwide dealer network

Options available include...

- Short feed tray with light tight cover
- Rear exit receiving and light trap kit
- Variable speed control
- Closed loop system (no external plumbing needed)
- Kit for processing of laser imaged film
- Receiving tray insert for full spine films
- Base stand

Affordably priced - the MicroMAX provides more features and benefits for less!

Can you afford less than the best? If your reputation for quality is important... remember, HOPE products deliver quality.

MicroMAX

Processing Time: (Leading edge to leading edge)*

- Standard Processing Cycle - 135 Seconds
- Intermediate Processing Cycle - 112 Seconds
- Rapid Processing Cycle - 90 Seconds
- * Other processing cycles available

Processing Capacity:

- Standard Process: 68 (10" x 12") films/hour; 45 (14" x 17") films/hour
- Rapid Process: 110 (10" x 12") films/hour; 70 (14" x 17") films/hour

Film Size:

From 4" x 4" (10cm x 10cm) up to 14" (35.5cm) wide by any standard length

Processor Tank Capacities:

Developer	1.2 gal / 4.3 ltr
Fixer	0.9 gal / 3.3 ltr
Wash	0.9 gal / 3.3 ltr

Electrical:

110V, 60 Hz, 14 amp
220V, 50/60 Hz, 7.5 amp - 1 ph

Water Requirements: (GPM)

Operating	0.25 GPM / .95 ltr
Standby	0.00 gal / 0.0 ltr

Dimensions:

Length (overall)	38.25" (97.2 cm)
Width	22.25" (56.5 cm)
Height (without base)	25.25" (64.1 cm)
Height (with base)	54.50" (138.43 cm)

Shipping Weight:

195 lb / 88.6 kg

Standard

Includes light tight covered feed tray, replenishment tanks, manual, spare parts kit and water supply hose.

Warranty

Hope X-Ray offers a one year warranty on all parts.

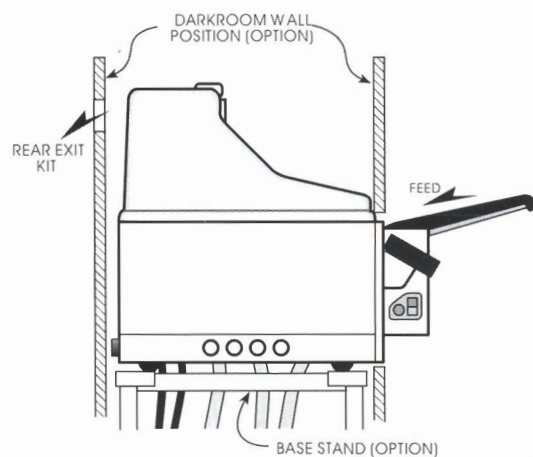
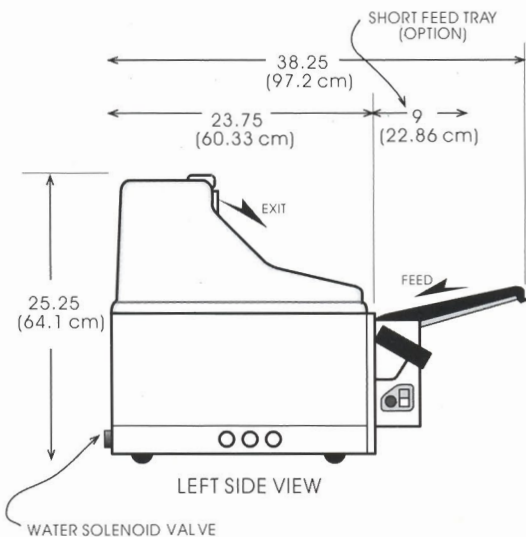
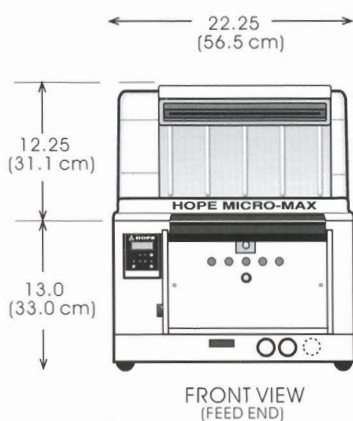

HOPE X-RAY PRODUCTS INC.

Distributed by

JD HONIGBERG INTERNATIONAL, Inc
85 Revere Drive, Ste D
Northbrook IL 60062 USA

Tel: 847 412 0200
Fax: 847 412 0034
E-Mail: medical@jdhintl.com

